

**TALO SUSPENSION
90-120-150-180-240**

**TALO SUSPENSION
CATAMARAN 90-120**

NEIL POULTON • 2002

SUSPENSION MOUNTED LUMINAIRES FOR DIRECT/INDIRECT ENERGY SAVING, HIGH EFFICIENCY FLUORESCENT LIGHTING.

AVAILABLE LENGTHS:
36", 48", 60", 71", 95"

- BODY WITH PROFILES IN EXTRUDED ALUMINUM AND END CAPS IN DIE-CAST ALUMINUM
- AVAILABLE IN WHITE OR SILVER GREY EPOXY POWDER COATING FINISH
- UPPER DIFFUSER IN CLEAR MOLDED POLYCARBONATE, LOWER DIFFUSER IN OPALINE MOLDED POLYCARBONATE
- SUSPENSION SUPPORTING/FEEDING CABLES WITH CLEAR TEFLON COATING
- CEILING CANOPY IN STEEL WITH COVER IN MOLDED THERMOPLASTIC WITH WHITE OR SILVER GREY POWDER COATING FINISH, MOUNTING TO STANDARD ELECTRICAL JUNCTION BOXES

HIGH OUTPUT FLUORESCENT SOURCE

TALO SUSPENSION 90 (36")

- 1 X 39W (G5/T5/HO)

TALO SUSPENSION 120 (48")

- 1 X 54W (G5/T5/HO)

TALO SUSPENSION 150 (60")

- 1 X 80W (G5/T5/HO)

TALO SUSPENSION 180 (71")

- 2 X 39W (G5/T5/HO)

TALO SUSPENSION 240 (95")

- 2 X 54W (G5/T5/HO)

**TALO SUSPENSION
CATAMARAN 90 (36")**

- 2 X 39W (G5/T5/HO)

**TALO SUSPENSION
CATAMARAN 120 (48")**

- 2 X 54W (G5/T5/HO)



TALO SUSPENSION CATAMARAN 90



TALO SUSPENSION 90

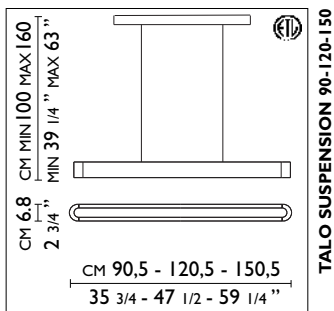

TALO SUSPENSION 90-120-150

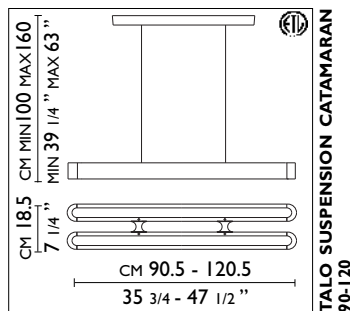

TALO SUSPENSION CATAMARAN 90-120

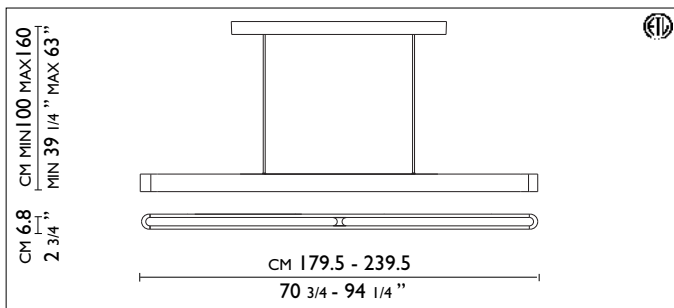

TALO SUSPENSION 180-240



TALO SUSPENSION 240

unica
HOME

www.unicahome.com
1-888-89-UNICA